

GENERAL CHARACTERISTICS



Piston flow switch float measuring principle. The flow working range depends from the differential pressure generated in the flow chamber. The adjustment is very simple and the setting mechanism has a safe locking system.

Electrical connection by DIN 43650-A plug.

Air and gas application

- Flow visual indication
- High switch accuracy
- Hermetic separation of mechanical and electrical components
- Free installation position



TECHNICAL DATA

Tab.1

DN	Ø	Type	P max Bar	T max °C		Adjustable range NI/min – Air (*)	Code Range
				L	H		
008	1/4"	VO.VL4-008.GM	16	100	160	0,2 - 1,3	L001
						0,5 - 2	L002
						0,8 - 3	L003
						1,5 - 5	L005
						2 - 8	L008
						3 - 12	L012
						3,5 - 14	L014
						5,5 - 20	L020
						7 - 24	L024
						10 - 35	L035
						10 - 42	L042

DN	Thread	UNI 228/1
Accuracy	± 10% F.S.	
Hysteresis	15% minimum 0,5 NI/min	
Pressure drop	0,02 to 0,2 bar	
(*) Air at 1 bar absolute and 20°C		

Adjustable ranges are indicated for horizontally decreasing flow

MATERIALS

Tab.2

	GM	GK
Housing (*)	Anodized aluminium	Anodized aluminium
Sight glass	Duran® 50	Duran® 50
Piston	Brass	St. steel 1.4571
Spring	St. steel 1.4571	St. steel 1.4571

(*) non wetted part

ELECTRICAL DATA

Tab.3

Description	Characteristics				
		200V	1,0A	20VA	S1
Contact	Reed	125V	1,0A	20VA	S3
		IP65	DIN 43650-C		S1
Electrical entry	Plug	M12x1 (*)		S3	

(*) T max -20 / +85°C only = X code

DRAWING

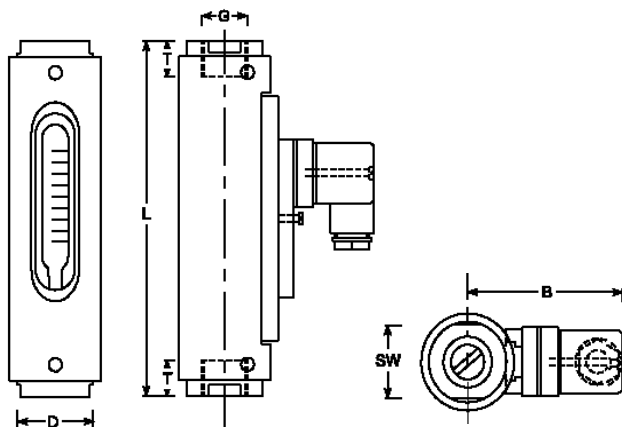

DIMENSIONS - mm

DN	SW	D	B	T	L	Kg
008	17	20	49	10	90	0,15

WIRING

Tab.4

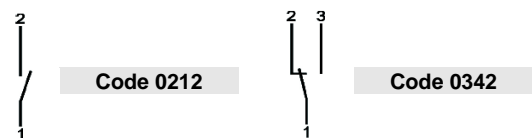

NOMENCLATURE

VO.VL4	008	GM	L002	S1	IP65-L	0212
•						
	•					
		•				
			•			
				•		
					•	
						•

	Type
Tab.1	Size and connections thread
Tab.2	Material
Tab.1	Adjustable range
Tab.3	Electrical connection and switch electrical data
Tab.1-3	Protection class – Temperature class
Tab.4	Wiring – Contact type